

# Fact Sheet

## A560

**BIZERBA**

*Benefit from an automated hardware and software solution with the A560. You slice, weigh and portion a large product variety to target weight with just one device. Produce order-based and increase your profits slice by slice.*



**More information**  
High performance  
with a wide range of  
solutions and options.

Specifications	Facts	Details
<b>Dimensions</b>		
<b>Installation area (L x W)</b>	1381 x 800 mm / 54.4" x 31.5"	
<b>Maximum dimensions (L x W x H)</b>	2320 x 800 x 1835 mm / 91.3" x 31.5" x 72.2"	Belt length: 1310 mm
<b>Electrical data</b>		
<b>Power consumption</b>	200 - 240 V; 50/60 Hz 400 V, 50 Hz, 5.6 A	Three-phase current Three-phase current
<b>IP rating</b>	IPx5	Suitable for hose cleaning, individual components can be cleaned in the dishwasher
<b>Performance data</b>		
<b>Product size</b>	Height: 30 - 180 mm / 1.2" - 7.1" Width: 50 - 210 mm / 2.0" - 8.3" Round: Ø 40 - 180 mm / 1.6" - 7.1" Length: 600 mm / 23.6"	
<b>Slicing performance</b>	40 - 250 slices per minute 40 - 200 slices per minute	Without scale With scale
<b>Slice thickness</b>	0.5 - 50 mm / 0.02" - 2.0"	
<b>Blade diameter</b>	420 mm / 16.5"	
<b>Housing materials</b>	Stainless steel and anodized aluminum Plastics	Complies with EU regulation No. 1935/2004 Complies with EU regulation No. 10/2011
<b>Packaging data</b>		
<b>Weight</b>	approx. 480 kg / 1058.2 lb	A550

Options	Facts	Details
<b>Discharge conveyor</b>	950 mm / 37.4" 1310 mm / 51.6" 2500 mm / 98.4"	Short/ Standard Long
<b>Scale</b>	Weighing range: 50 - 2000 g / 0.1 - 4.5 lb Interval: 1 g / 0.002 lb	

### Info graphics



---

**Symbols**



---

## Dimensional drawings

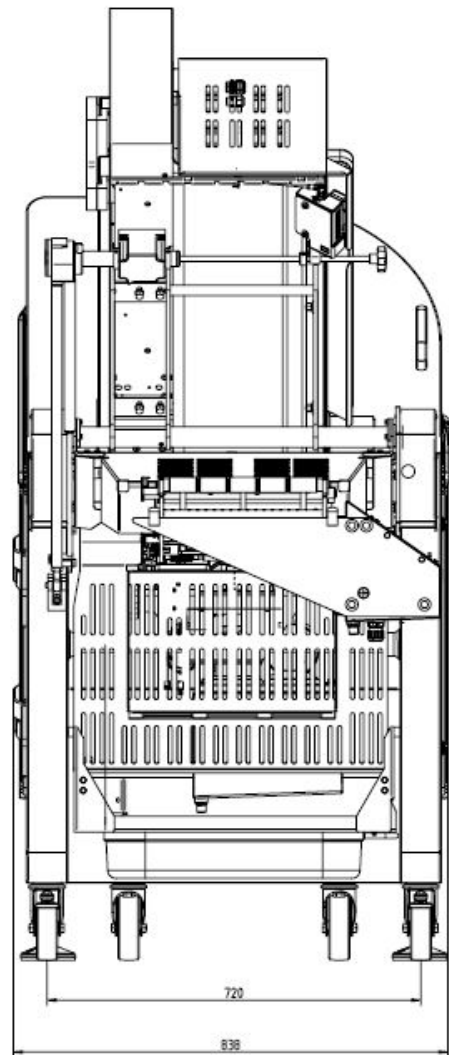
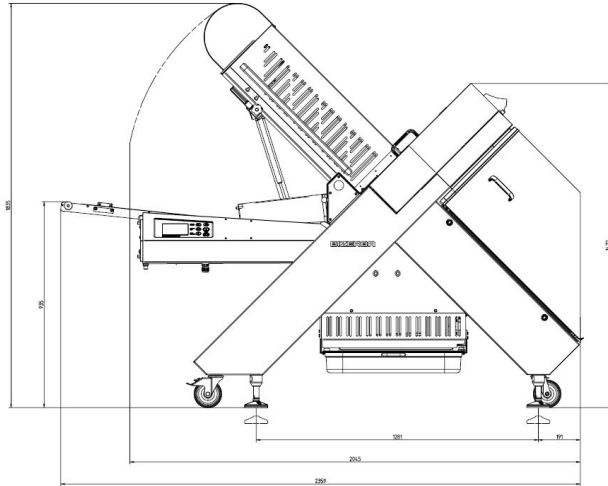

### A560

---

**Bizerba SE & Co. KG**  
Wilhelm-Kraut-Straße 65  
72336 Balingen

T +49 7433 12-0  
fax: +49 7433 12-2696  
marketing@bizerba.com

**[www.bizerba.com](http://www.bizerba.com)**