

# Fact Sheet

## VSI F

**BIZERBA**

*Intelligent slicing – the fully automatic vertical slicer VSI F combines precision and slicing to target weight and a networked integration in the production process. The individual solution for more flexibility and efficiency.*



**More information**  
High performance  
with a wide range of  
solutions and options.

Specifications	Facts	Details
<b>Dimensions</b>		
<b>Outer dimensions L x W x H</b>	743 x 1087 x 772 mm 743 x 1272 x 772 mm	400 mm carriage 600 mm carriage
<b>Installation area L x W</b>	609 x 631 mm	400 mm carriage, 600 mm carriage
<b>Work area L x W x H</b>	822 x 1182 x 772 mm 810 x 1367 x 772 mm	400 mm carriage 600 mm carriage
<b>Electrical data</b>		
<b>Power consumption</b>	120 V; 5.5 A; 60 Hz 110-127 V; 5.5 A; 50/60 Hz 220-240 V; 2.9 A; 50/60 Hz 100 V; 6.6 A; 50/60 Hz	1-phase alternating current 1-phase alternating current 1-phase alternating current 1-phase alternating current
<b>IP rating</b>	IPx5	Suitable for hose cleaning, individual components can be cleaned in the dishwasher
<b>Performance data</b>		
<b>Product size</b>		
<b>L x W x H</b>	400 x 240 x 180 mm 600 x 240 x 180 mm	400 mm carriage 600 mm carriage
<b>Round Ø</b>	180 mm	400 mm carriage, 600 mm carriage
<b>Blade diameter</b>	330 mm	
<b>Blade speed</b>	160 - 300 rpm	Adjustable in increments of 10
<b>Blade alignment</b>	0° inclination	
<b>Slice thickness</b>	0.3-12 mm	Motorized adjustment
<b>Slicing performance</b>	30 - 80 slices per minute	Slicing performance depending on depositing type and product
<b>Carriage angle</b>	0°	
<b>Housing materials</b>	Stainless steel and anodized aluminum Plastics	Complies with EU regulation No. 1935/2004 Complies with EU regulation No. 10/2011
<b>Weight</b>		
<b>Machine weight</b>	approx. 122 kg	VSI without stand
<b>Packaging data</b>		
<b>Dimensions L x W x H</b>	680 x 1080 x 995 mm 680 x 1375 x 995 mm	400 mm carriage 600 mm carriage
<b>Packaging weight</b>	approx. 154 kg	

Options	Facts	Details
<b>Integrated portion scale</b>	50-2000 g	Weighing range

Info graphics



Symbols



CE

Dimensional drawings

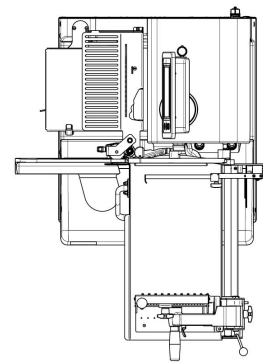
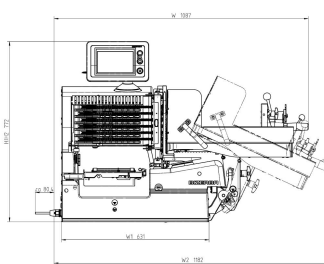
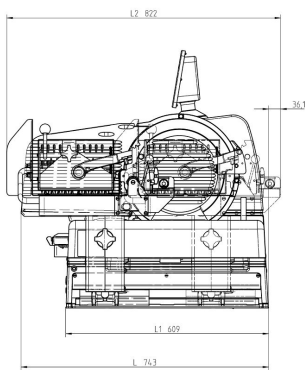

VSI F 400 mm carriage

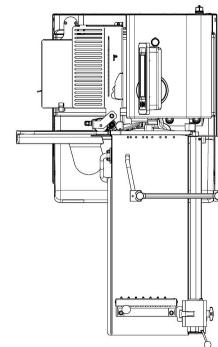
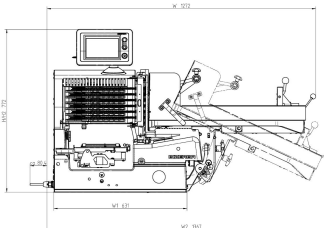
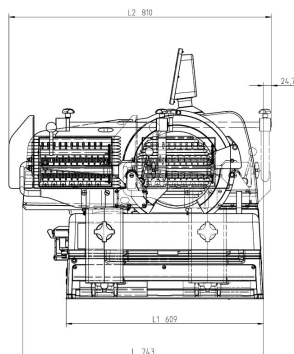

---

**VSI F 600 mm carriage**

---

**Bizerba SE & Co. KG**

Wilhelm-Kraut-Straße 65  
72336 Balingen

T +49 7433 12-0  
fax: +49 7433 12-2696  
marketing@bizerba.com

**[www.bizerba.com](http://www.bizerba.com)**