

# Fact Sheet

## VSP

**BIZERBA**

*This manual vertical slicer offers you a unique high-end performance package. Simplify your processes with the intelligent support SmarterSlicing: The digital display will automatically indicate you when it's time to clean, sharpen or maintain the VSP. Your benefits: You ensure high quality of your products and optimize your processes.*



**More information**  
High performance  
with a wide range of  
solutions and options.

Specifications	Facts	Details
<b>Dimensions</b>		
<b>Outer dimensions L x W x H</b>	628 x 563 x 432 mm	330, standard model
	627 x 649 x 432 mm	330, model with wider carriage
<b>Installation area L x W</b>	520 x 430 mm	330, standard model and model with wider carriage
<b>Work area L x W x H</b>	673 x 678 x 454 mm	330, standard model
	780 x 763 x 438 mm	330, model with wider carriage
<b>Electrical data</b>		
<b>Power consumption</b>	100-120 V; 50/60 Hz; 1.9-2.3 A	1-phase alternating current with Emotion®
	220-240 V; 50/60 Hz; 1.0 A	1-phase alternating current with Emotion®
<b>IP rating</b>	IP33	
<b>Performance data</b>		
<b>Product size</b>		Model
<b>Quadratic W x H</b>	260 x 180 mm	330, standard
	300 x 175 mm	330, wider carriage
<b>Round Ø</b>	225 mm	330, standard and with wider carriage
<b>Blade Ø</b>	330 mm	
<b>Blade speed</b>	160-300 rpm	Adjustable via HMI
<b>Blade alignment</b>	0° inclination	
<b>Slice thickness</b>	0-24 mm	Infinitely adjustable
	0-3 mm	Fine adjustment
<b>Slicing performance</b>	-	
<b>Carriage angle</b>	0°	
<b>Housing material</b>	Anodized aluminum Bizerba Ceraclean® Plastics	
<b>Weight</b>		
<b>Machine weight</b>	approx. 46 kg	330, standard model and model with wider carriage
<b>Packaging data</b>		
<b>Dimensions L x W x H</b>	830 x 745 x 700 mm	330, standard model
	830 x 790 x 700 mm	330, model with wider carriage
<b>Packaging weight</b>	approx. 55 kg	330, standard model and model with wider carriage

Options	Facts	Details
Integrated portion scale	0-3000 g	Weighing range
	2 g	Interval
Integrated metrologically approved scale	0-3000 g and 0-6000 g	Weighing range
	1 g and 2 g	Interval

**Info graphics**



VSP standard version

**Symbols**



**Dimensional drawings**

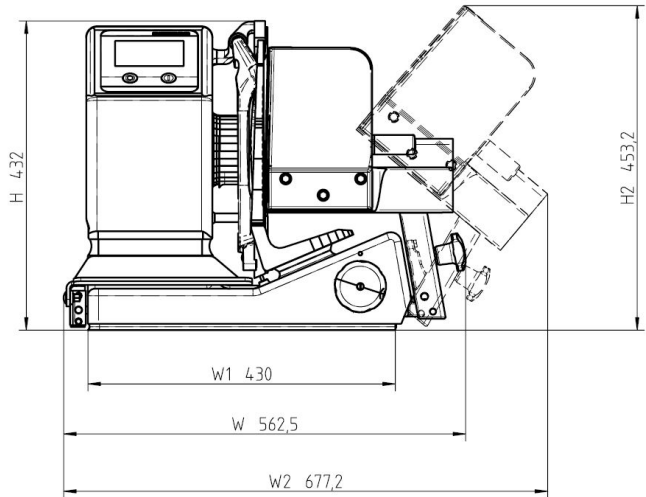
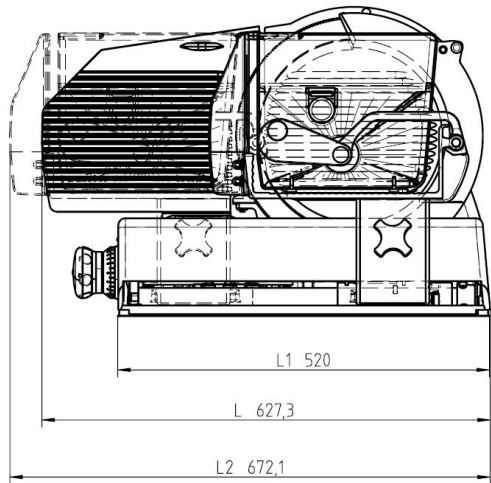

VSP standard version

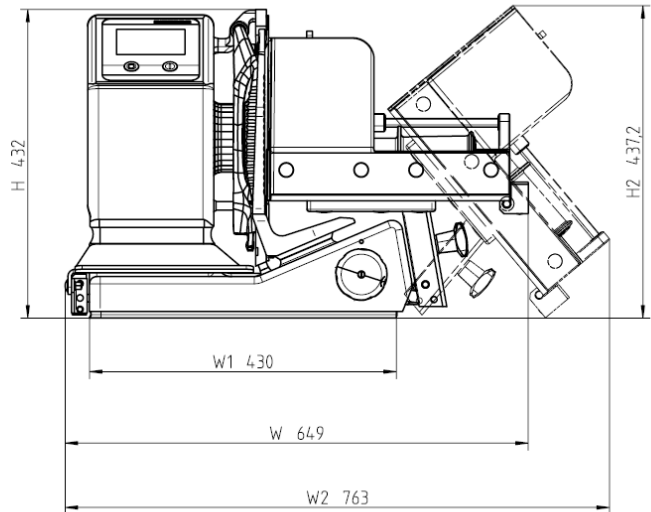
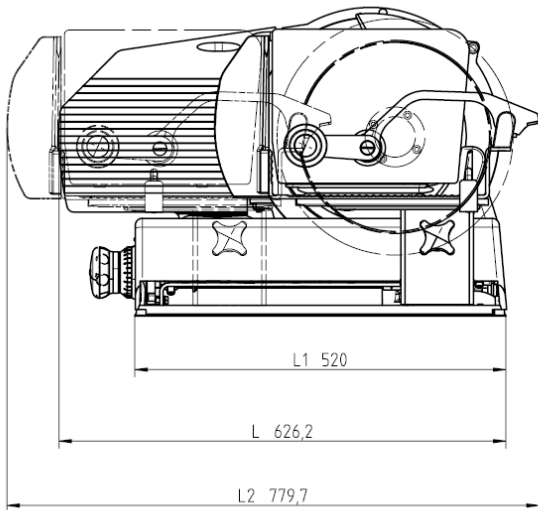

VSP version with wider carriage

**Bizerba SE & Co. KG**  
 Wilhelm-Kraut-Straße 65  
 72336 Balingen

T +49 7433 12-0  
 fax: +49 7433 12-2696  
 marketing@bizerba.com

[www.bizerba.com](http://www.bizerba.com)